

Models

- PLF3CP delivers 3 gph of chilled drinking water.
- PLF3CPH is a Hot 'N Cold and serves 45 cups of piping hot water, plus 3 gph of chilled water.
- PLF5CP delivers 5 gph of chilled drinking water.
- PLF10CP delivers 10 gph of chilled drinking water.

Standard Features

- Waterways Are Lead-Free In Materials & Construction
- Stainless Steel Top
- Dial-A-Drink® Bubbler
- Flexible Bubbler Guard
- Heavy-Gauge Steel Cabinet with Separate Base
- High-Efficiency Cooling Tank and Coil
- Refrigerant R-134a
- Limited 5-Year Warranty

Installation

- Prior to roughing-in, consult with local, state, and federal codes.
- Shipped with complete instructions.

Colors

- Standard Cabinet Finish: Mocha Tan Acrylic Enamel
- Optional finishes at extra cost: Stainless Steel and Baked Enamel finishes
 - Specify Finish _____

Accessories

Glass Fillers

- Push Handle 029603-004
- Push Back 029603-005
- Push Down 029603-006
- Kit 031505-001 is required for Field Installation of the above glass fillers (except Model PLF3CPH).

Limited 5-Year Warranty (Continental limits of the United States and Canada): Five years on the sealed refrigeration system and most component parts. Detailed warranty certificate enclosed with each water cooler; sample copy available upon request.

Components in these water coolers/fountains are lead free as defined by the Safe Drinking Water Act Amendments of 1986, and the Lead Contamination Control Act of 1988.

*Air Conditioning and Refrigeration Institute Standard Rating Condition 80°F inlet water temperature.

** Special export models available, operable on 220-240 volts, 50/60 Hz. UL, CSA and ARI certification not applicable.

***Hot 'N Cold™ Model delivers 45 six-ounce cups of water per hour in addition to cold water.

**WATER COOLERS
FREE-STANDING**



A compact, attractive economical line suitable for a variety of applications in offices, shops, or factories where space savings is critical.

Model PLF3CP Shown



Models covered by these specifications comply with all known Plumbing Codes. Listed by Underwriter's Laboratories. Certified by Canadian Standards Association, and Certified to Air Conditioning and Refrigeration Institute Standard 1010.



Indicates conformity to European Union Directives.

Export Warranty: One year on the sealed refrigeration system and most component parts. Four-year replacement contract on sealed refrigeration system. Detailed warranty certificate enclosed with each water cooler, sample copy available upon request.

Specifications are subject to change without notice.

Copyright 1999 OASIS Corporation

Oasis® and Dial-A-Drink® are registered trademarks of OASIS Corporation.

Model	50°F Drinking Water 90°F Ambient Air Temperature*		Pre-Cooler	Hot 'N Cold Model	115 Volts, 60 Hz			Glass Filler Accessory Option	Cabinet Color Option	Net Weight (Approx.)
	Rated Capacity GPH	Base Rate GPH			Compr. HP	Full Load Amps	Rated Watts			
PLF3CP**	3.0	3.0	No	No	1/8	2.2	170	Yes	Yes	66 Lbs.
PLF3CPH***	3.0	3.0	No	Yes	1/8	6.5	670	No	Yes	66 Lbs.
PLF5CP	5.0	5.0	No	No	1/5	3.6	250	Yes	Yes	69 Lbs.
PLF10CP**	10.0	10.0	No	No	1/3	5.6	510	Yes	Yes	70 Lbs.

OASIS Corporation

Distribuidor: Novo Agua SA de CV. Tel: 0181-8129-5307, tel y fax: 8311-8352

Oasis® is a registered trademark of OASIS Corporation
 Specifications are subject to change without notice
 Copyright 1999 OASIS Corporation

OASIS Corporation
 265 North Hamilton Road ♦ PO Box 13150
 Columbus, Ohio

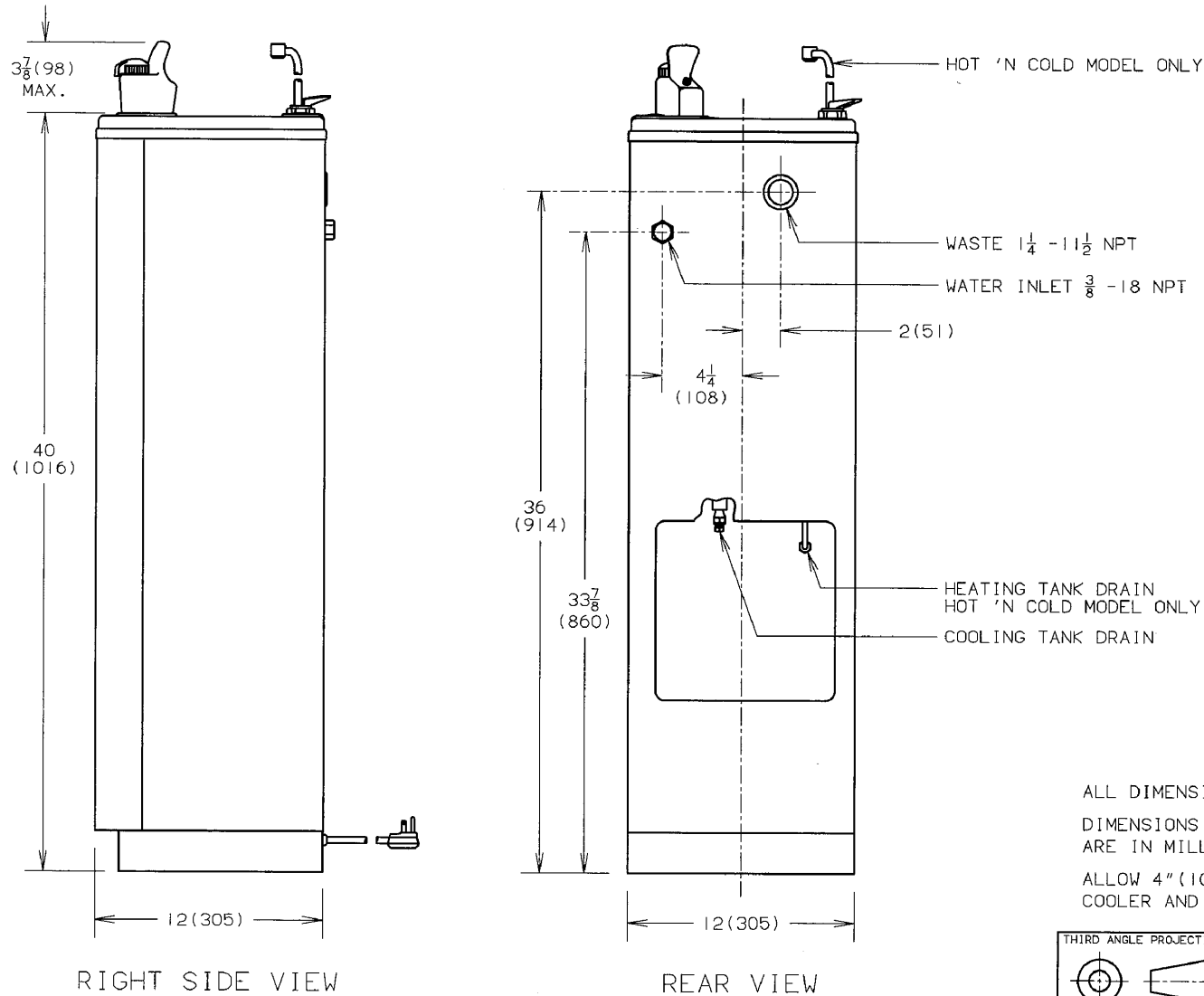

Distribuidor:
 Novo Agua SA de CV
 Tel: 8129-5307
 Tel y fax: 8311-8352

ALL DIMENSIONS ARE IN INCHES.
 DIMENSIONS IN PARENTHESES ()
 ARE IN MILLIMETERS.
 ALLOW 4" (102) BETWEEN REAR OF WATER
 COOLER AND WALL FOR VENTILATION.

THIRD ANGLE PROJECTION 	ROUGHING-IN AND DIMENSIONAL DRAWING
----------------------------	---

Models PLF3CP, PLF3CPH, PLF5CP, and PLF10CP