



Free Standing

P3CP, P5CP, and P10CP

Suggested Specification

Model P3CP shall deliver 3 gph of 50°F water at 80°F inlet water and 90°F ambient (room) temperature. **Model P5CP** shall deliver 5 gph of 50°F water at 80°F inlet water and 90°F ambient (room) temperature. **Model P10CP** shall deliver 10 gph of 50°F water at 80°F inlet water and 90°F ambient (room) temperature.

Bubbler shall have flexible guard, lever handle, and built-in pressure regulator to deliver smooth steady flow at supply pressures of 20 to 120 psi. Basin shall be designed to eliminate splashing and standing water. Cabinet finish shall be Sandstone or Dove Gray **powder coated** paint on galvanized steel or brushed stainless steel. Base shall be constructed of galvanized steel. Cooling system shall use R-134a refrigerant.

Shall be listed by Underwriters Laboratories, certified to the Air Conditioning and Refrigeration Institute Standard 1010, certified by Canadian Standard Association and conform to European Union Directives. Shall comply with ANSI/NSF 61.

Models

- P3CP** Delivers 3 gph of chilled drinking water
- P5CP** Delivers 5 gph of chilled drinking water
- P10CP** Delivery 10 gph of chilled drinking water

Standard Features

- Waterways are lead-free in materials and construction
- Dial-A-Drink® Bubbler with flexible guard
- Stainless steel top
- Heavy-gauge steel cabinet with separate galvanized steel base
- High-efficiency cooling tank and coil
- Refrigerant R-134a
- Limited 5-year warranty

Finishes

- Standard Cabinet Finish: Sandstone **powder coat** paint
- Optional Finish At No Extra Cost: Dove Gray **powder coat** paint
- Optional Finish At Extra Cost: Stainless Steel
- Optional Finishes At Extra Cost: White and Black **powder coat** paint



Accessories

Glass Fillers

- Glass Filler – push handle (029603-004)
- Glass Filler – push back (029603-005)
- Glass Filler – push down (029603-006)
- Kit (031505-001) is required for field installation for the above glass fillers



Components in this fountain are lead free as defined by the Safe Drinking Water Act Amendments of 1986, and the Lead Contamination Control Act of 1988.

Limited 5-Year Warranty (Continental limits of the United States and Canada): Five-years on the sealed refrigeration system and most component parts. Detailed warranty certificate enclosed with each water cooler; sample copy available upon request.

Powder Coated Finish Warranty (Continental limits of the United States and Canada): Three-years on the powder coat paint finish in normal use.

Export Warranty: One-year on sealed refrigeration system and most component parts. Four-year replacement contract on sealed refrigeration system. Detailed warranty certificate enclosed with each drinking fountain; sample copy available upon request.

Models covered by this specification comply with all known Plumbing Codes. Listed by Underwriters' Laboratories. Certified by Canadian Standards Association, and Certified to Air Conditioning and Refrigeration Institute Standard 1010.



Model	50°F Drinking Water 90°F Ambient Air Temperature*			115 Volts, 60 HZ		Glass Filler Acc. Option	Net Wt. Approx.
	Rated Capacity GPH	Base Rate GPH	Pre-Cooler	Full Load Amps	Rated Watts		
P3CP**	3.0	3.0	No	3.3	280	Yes	66 Lbs.
P5CP	5.0	5.0	No	3.3	280	Yes	69 Lbs.
P10CP**	10.0	10.0	No	5.2	510	Yes	70 Lbs.

*Air Conditioning and Refrigeration Institute Standard Rating Condition 80°F inlet water temperature.
 **Special Export models available, operable on 220-240 volts, 50/60 Hz, UL, CSA, and ARI certification not applicable.

OASIS® WATER COOLER MODELS P3CP, P5CP, P10CP

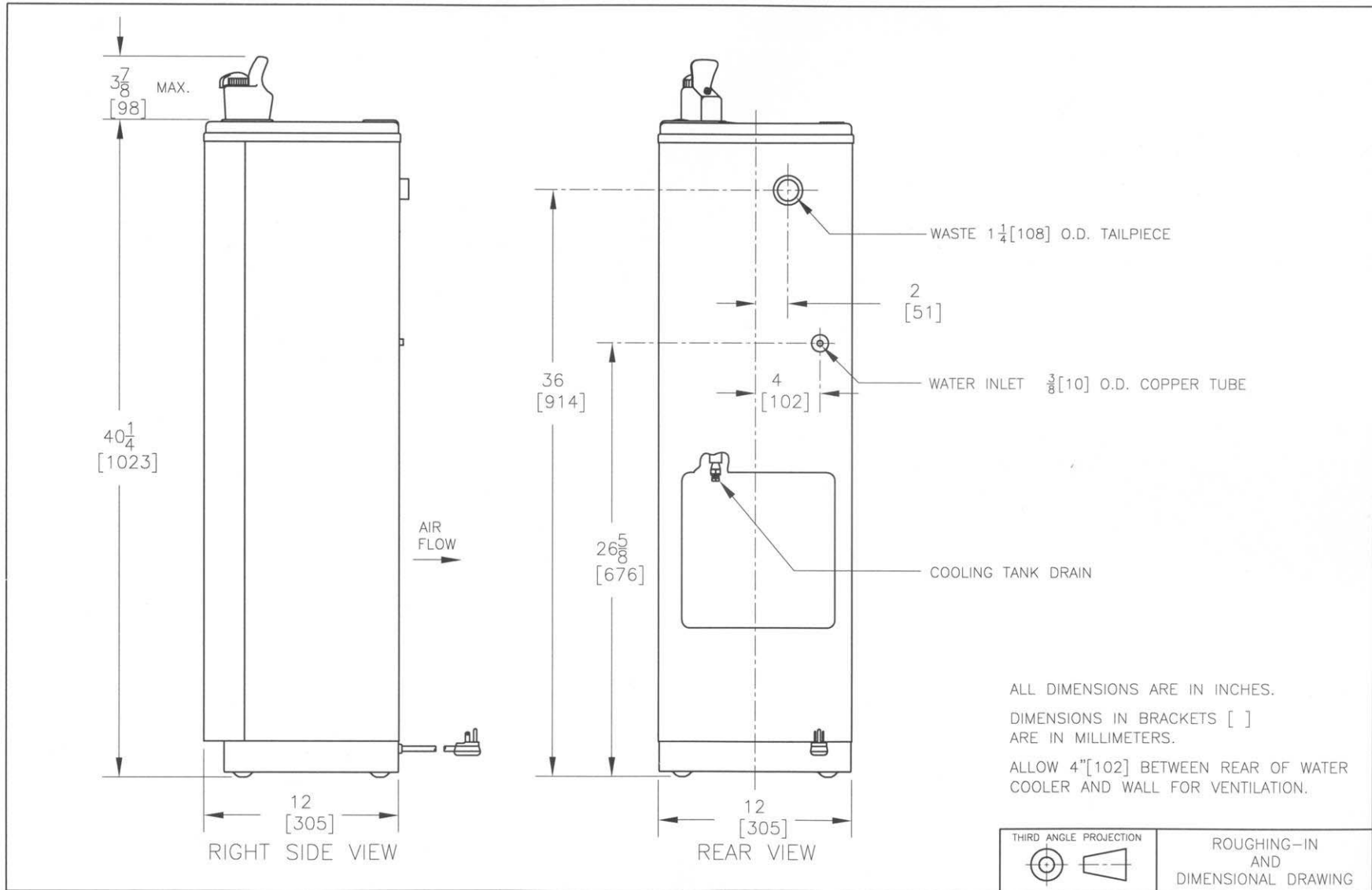

OASIS Corporation
 265 N. Hamilton Road
 Columbus, Ohio 43213

OASIS®, OASIS®, and Dial-A-Drink®
 are Registered Trademarks of OASIS Corporation
 © 2002 OASIS Corporation