

Model

- ❑ FLF120 is a non-refrigerated stainless steel drinking fountain for direct connection to a cold water supply or for use with remote water chillers.

Standard Features

- Waterways Are Lead-Free In Materials & Construction
- Stainless Steel Basin
- Dial-A-Drink® Bubbler
- Chrome-Plated Brass Strainer and Tailpiece
- Limited 1-Year Warranty

Installation

- Prior to roughing-in, consult with local, state, and federal codes.
- Shipped with complete instructions and wall mounting bracket.

Colors

- ❑ Standard Bowl Finish: Stainless Steel

Limited 1-Year Warranty (Continental limits of the United States and Canada): One year from date of installation on parts only. Detailed warranty certificate enclosed with each drinking fountain; sample copy available upon request.

Components in this drinking fountain are lead free as defined by the Safe Drinking Water Act Amendments of 1986, and the Lead Contamination Control Act of 1988.

**DRINKING FOUNTAINS
BRACKET MOUNTED**



Model FLF120 Shown



Model covered by these specifications complies with all known Plumbing Codes. Certified by Canadian Standards Association.

Export Warranty: One year on component parts. Detailed warranty certificate enclosed with each drinking fountain, sample copy available upon request.

Specifications are subject to change without notice.

Copyright 1999 OASIS Corporation

Oasis® and Dial-A-Drink® are registered trademarks of OASIS Corporation.

Model	Style	Physical Dimensions In Inches			Extended From Wall	Net Weight (Approx.)
		Height	Width	Depth		
FLF120	Bracket Mounted On-A-Wall	9-3/16	13	13-3/32	13-3/32	6 Lbs.

Distribuidor:
Novo Agua SA de CV
Tel: (0181)8129-5307
Tel y fax: 8311-8352

OASIS Corporation

265 North Hamilton Road ♦ PO Box 13150
Columbus, Ohio 43213-0150 U.S.A

Oasis® is a registered trademark of OASIS Corporation
 Specifications are subject to change without notice
 Copyright 1999 OASIS Corporation

OASIS Corporation
 265 North Hamilton Road • PO Box 13150
 Columbus, Ohio 43213-0150 U.S.A.

DIMENSIONAL DRAWING

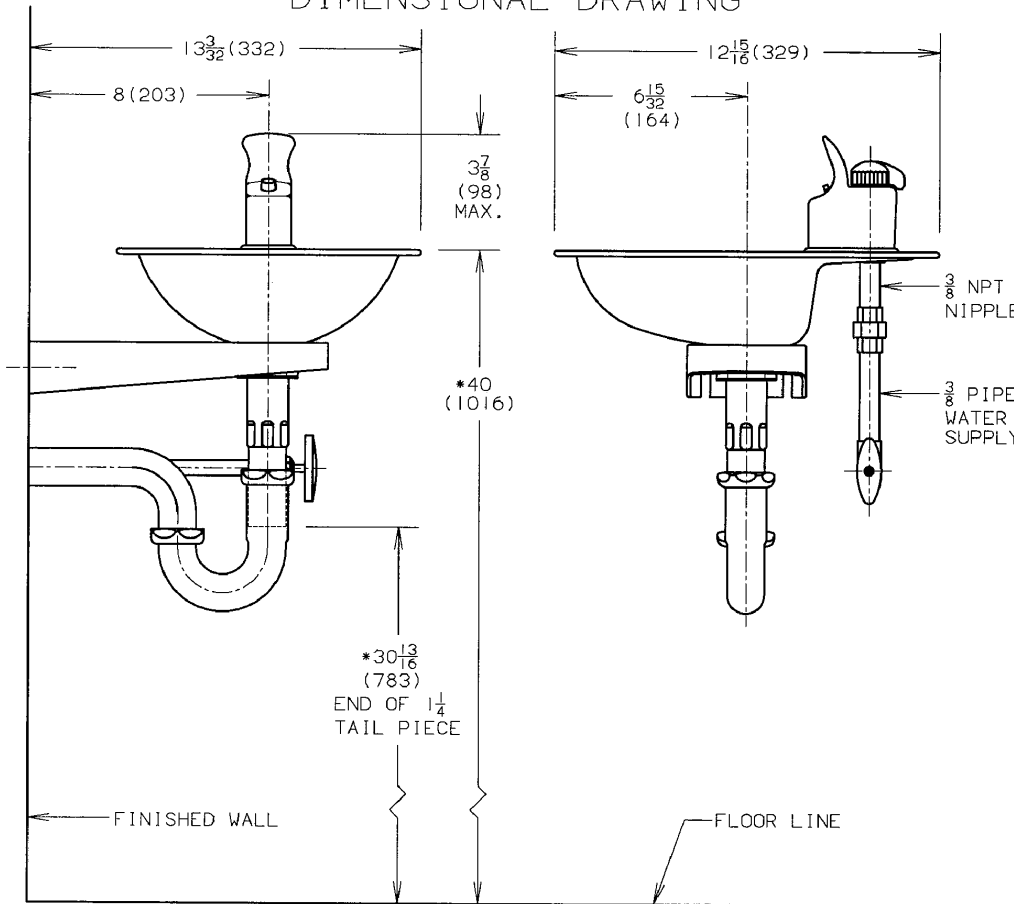

ROUGHING-IN DRAWING

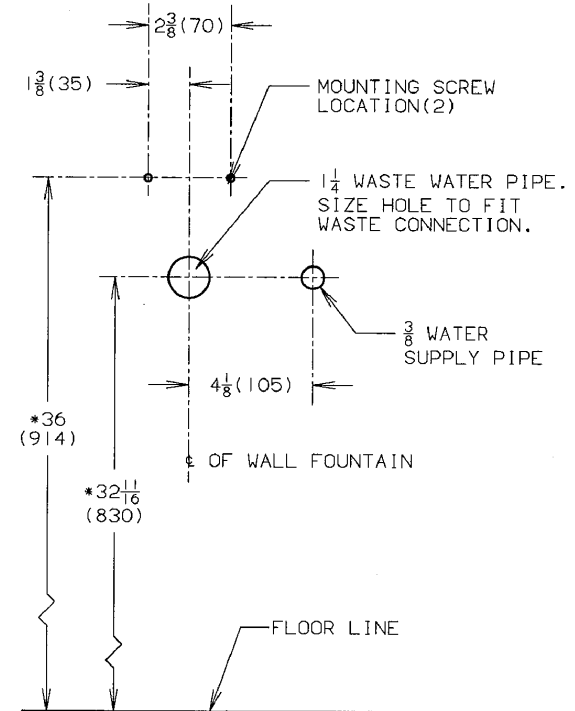

TRAP, FIXTURE STOP VALVE, $\frac{3}{8}$ WATER SUPPLY PIPES, AND UNION NOT FURNISHED WITH DRINKING FOUNTAIN. ALL DIMENSIONS ARE IN INCHES. DIMENSIONS IN PARENTHESES () ARE IN MILLIMETERS.

*RECOMMENDED ADULT HEIGHT INSTALLATION SHOWN. ADJUST VERTICAL DIMENSIONS AS REQUIRED TO COMPLY WITH FEDERAL, STATE AND LOCAL CODES.

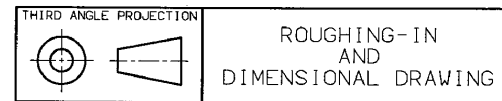

Model FLF120